

L6E3

Capacity: 200kg

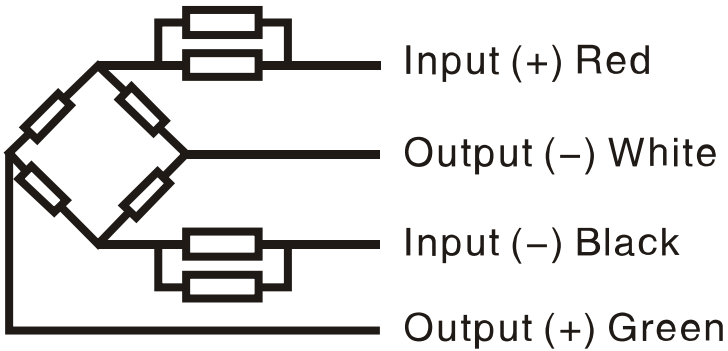
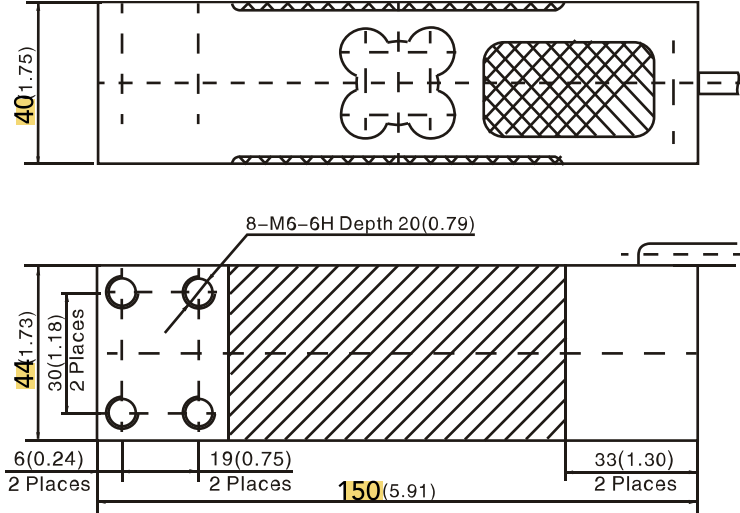
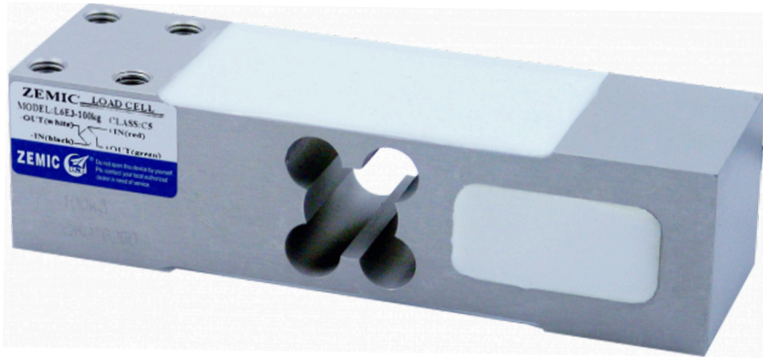

Wiring:

Adopt a shielded, 4 conductor cable, and cable jacket is PVC.

Cable length: 3 ± 0.1 m

Cable diameter: 5.3 ± 0.2 mm

Specifications		Capacity		
		50/100/150/200/250/300/500		
Capacity	kg			
Accuracy		C3D	C3	C3G
Approvals			OIML R60 C3	
Maximum number of verification intervals	n _{max}	2500	3000	4000
Minimum load cell verification interval	v _{min}	E _{max} /5000	E _{max} /7000	E _{max} /11000
Combined error	(%FS)	≤ ±0.030	≤ ±0.020	≤ ±0.015
Creep	(%FS/30min)	≤ ±0.020	≤ ±0.0167	≤ ±0.0125
Temperature effect on sensitivity	(%FS/10°C)	≤ ±0.021	≤ ±0.0175	≤ ±0.0131
Temperature effect on zero	(%FS/10°C)	≤ ±0.028	≤ ±0.020	≤ ±0.0127
Output sensitivity	(mv/v)		2.0 ± 0.2	
Input resistance	(Ω)		409 ± 6	
Output resistance	(Ω)		350 ± 3	
Insulation resistance	(MΩ)		≥ 5000 (50VDC)	
Zero balance	(%FS)		2	
Temperature, compensated	(°C)		-10 ~ +40	
Temperature, operating	(°C)		-35 ~ +65	
Excitation, recommended	(V)		5 ~ 12 (DC)	
Excitation, max	(V)		18 (DC)	
Safe overload	(%FS)		150	
Ultimate overload	(%FS)		300	
Corner correction				0.02% load value/100mm